

ON AUMANN'S THEOREM THAT THE SPHERE DOES NOT ADMIT A MEAN

F. JAVIER TRIGOS-ARRIETA AND MARIAN TURZAŃSKI

ABSTRACT. We prove that the circle S_1 does not have a 2-mean, i.e., $S_1 \times S_1$ cannot have a retraction r onto its diagonal with $r(x, y) = r(y, x)$, whenever $x, y \in S_1$. Our proof is combinatorial and topological rather than analytical.

1. INTRODUCTION

AUMANN and CARATHEODORY [1], [2] and [3] were among the pioneers who first considered the question about the structure of spaces for which the topological product X^n has a symmetric retraction onto its diagonal, i.e., a n -mean. They studied such objects in the complex plane and in the Euclidean n -space using analytical tools. For example AUMANN in [3] proved that the n -dimensional sphere does not have a mean. For more information about means see [8]. The aim of this note is to prove that the circle S_1 does not have a 2-mean, using only combinatorial and topological tools. For this purpose we use a method comparable to the one used in [10]. It is interesting to notice that this method has been used (in dimension 2) to prove, among some other results, the BROUWER fixed point theorem and the special hexagonal chessboard theorem (see GALE [6], who, as far as we know, introduced the method), and the BORSUK-ULAM antipodal theorem (see [12]). We point out that in the case of the BROUWER fixed point theorem, the combinatorial proof in [9] is based on SPERNER'S Lemma [14] but in the case of the BORSUK-ULAM antipodal theorem [4], for the combinatorial proof TUCKER'S Lemma [15] is used (in this case SPERNER'S Lemma is not enough) (KY FAN [7] extended TUCKER'S result to arbitrary n). For more information about fixed point theory see [5]. Here we have (in dimension 2) one universal combinatorial lemma (see next section). We wonder if it is possible to generalize this method to arbitrary n .

2. COMBINATORIAL PART

Let us fix a natural number $k > 1$ and let

$$Z_k = \left\{ \frac{i}{k} : i \in \{0, \dots, k\} \right\}$$

Date: June 2003. Work in Progress.

and denote by

$$D^2(k) = (Z_k \times Z_k) = \left\{ 0, \frac{1}{k}, \dots, \frac{k-1}{k}, 1 \right\}^2;$$

$D^2(k)$ is called a *combinatorial square*.

Definition 1. Denote by $\mathbf{e}_0 = (\frac{1}{k}, 0)$, $\mathbf{e}_1 = (0, \frac{1}{k})$ the basic vectors of length $\frac{1}{k}$. An ordered set $z = [z_0, z_1, z_2]$ is said to be a *simplex* if and only if

$$z_1 = z_0 + \mathbf{e}_i, z_2 = z_1 + \mathbf{e}_{1-i} \quad \text{where } i \in \{0, 1\}.$$

Any subset $[z_0, z_1]$, $[z_1, z_2]$ and $[z_2, z_0] \subset z$ is said to be a face of the simplex z .

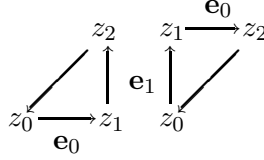

FIGURE 1

Observation 1. Any face of a simplex z contained in $D^2(k)$ is a face of exactly one or two simplexes from $D^2(k)$, depending on whether or not it lies on the boundary of $D^2(k)$.

Definition 2. Let $\mathcal{P}(k)$ be the family of all simplexes in $D^2(k)$ and let $\mathcal{V}(k)$ be the set of all vertices of the simplexes from $\mathcal{P}(k)$. A *coloring* of $\mathcal{P}(k)$ is any function $f : \mathcal{V}(k) \rightarrow \{1, -1\}$, and any face s of any simplex z is called an *f-gate* (or simply a gate if there is no ambiguity of what f is) if $f[s] = \{1, -1\}$.

Observation 2. Let w be a simplex, \mathcal{W} be the set of vertices of w and $f : \mathcal{W} \rightarrow \{1, -1\}$ be a function. Then w has an even number of gates.

Definition 3. If $f : \mathcal{V}(k) \rightarrow \{0, 1\}$ is a function, two simplexes w and v from $\mathcal{P}(k)$ are in the relation \sim if $w \cap v$ is a gate. A subset $\mathcal{S} \subset \mathcal{P}(k)$ is called a chain in $\mathcal{P}(k)$ if $\mathcal{S} = \{w_0, w_1, \dots, w_n\}$ and for each $i \in \{0, \dots, n-1\}$, $w_i \sim w_{i+1}$.

Observation 3. For each chain $\{v_1, \dots, v_n\} \subset \mathcal{P}(k)$ there exists no more than one $v \in \mathcal{P}(k)$ and one $w \in \mathcal{P}(k)$ such that $\{v_1, \dots, v_n, v\}$ and $\{w, v_1, \dots, v_n\}$ are chains. Also, if \mathcal{S}_1 and \mathcal{S}_2 are maximal chains in $\mathcal{P}(k)$, then either $\mathcal{S}_1 \cap \mathcal{S}_2 = \emptyset$ or $\mathcal{S}_1 = \mathcal{S}_2$.

Let a and b be two different elements of $D^2(k)$. Consider the rectangle R with a and b as opposites vertices and right-hand-orient its boundary. By \overline{ab} we mean the part of the boundary that goes from a to b . We define similarly \overline{ba} . The boundary of R is denoted by ∂R .

Lemma 1. *No maximal chain $\mathcal{S} \subseteq \mathcal{P}(k)$ ever finishes at a gate of an interior simplex, i.e., a simplex disjoint from ∂R .*

Proof. It consists to show that if a simplex S_1 in \mathcal{S} is disjoint with ∂R , there is always another simplex S_2 with a common gate (Observation 2). Thus the only possibility for \mathcal{S} to stop is at ∂R . There are twelve possible (simplex, flow of the chain (if directed)) combinations of the simplex to be considered, each of them with two possible outcomes. We picture some of them with the following in mind: arrows mean flow, thick lines are NOT gates and thin lines are gates:

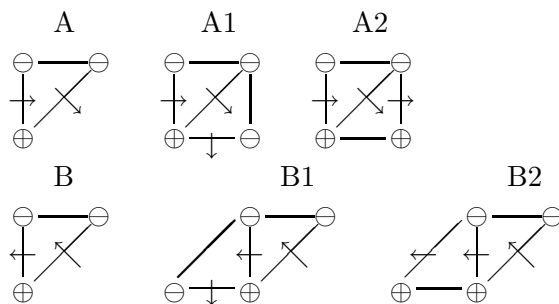

FIGURE 2

□

Corollary 1. *Any maximal chain $\mathcal{S} \subseteq \mathcal{P}(k)$ beginning at ∂R must finish at ∂R .*

Combinatorial Lemma. *Let $\mathcal{P}(k)$ be the set of simplexes of $D^2(k)$ and $f : \mathcal{V}(k) \rightarrow \{-1, 1\}$ be a coloring of $\mathcal{V}(k)$. If a and b belong to $\mathcal{V}(k)$, and $f(b) = -f(a)$, then there exists a chain $\mathcal{S} \subseteq \mathcal{P}(k)$ such that $\mathcal{S} \cap \overline{ab} \neq \emptyset \neq \mathcal{S} \cap \overline{ba}$.*

This result was proved originally in [16]. Here we present a different argument.

Proof. We first define two equivalence relations on $\mathcal{V}(k)$:

If $u, v \in D^2(k) \cap R$, we will say that $u \approx v$ if $u = v$ or if there are vertices $u = x_0, x_1, \dots, x_{n-1}, x_n = v$ in $D^2(k) \cap R$ such that $[x_i, x_{i+1}]$ is a face of a simplex ($i = 0, \dots, n-1$) and $f(x_i) = f(x_{i+1})$. Clearly \approx is an equivalence relation on $D^2(k) \cap R$.

Let $\mathcal{S} \subseteq \mathcal{P}(k)$ be a maximal chain beginning at the boundary of R . If $u, v \in D^2(k) \cap R$, we will say that $u \simeq v$ if $u = v$ or if there are vertices $u = x_0, x_1, \dots, x_{n-1}, x_n = v$ in $D^2(k) \cap R$ with $[x_i, x_{i+1}]$ being a face of a simplex ($i \in \{0, \dots, n-1\}$) and no $[x_i, x_{i+1}]$ is a gate belonging to a simplex belonging to \mathcal{S} . Clearly \simeq is an equivalence relation on $D^2(k) \cap R$ as well.

Let \mathcal{C} be the \approx -component of b . Walking from a to b let x be the vertex on \overline{ab} found right before $\mathcal{C} \cap \overline{ab}$, and y be the vertex on \overline{ab} right after x . Then

$y \in \mathcal{C}$ and $f(x) = f(a)$. Thus $[x, y]$ is a gate. Let \mathcal{S} be the unique maximal chain to which the simplex containing $[x, y]$ belongs to (Observation 3). By Corollary 1, \mathcal{S} ends on ∂R . By the choice of x and y and since points in \mathcal{C} are all \simeq -equivalent, \mathcal{S} must end on $\bar{b}a$, as required. \square

3. TOPOLOGICAL PART

We borrow the following from [10].

Definition 4. If $\{A_m : m \in \mathbb{N}\}$ is a sequence of subsets of a compact metric space X , we define its *upper limit* $Ls\{A_n : n \in \mathbb{N}\}$ as the set of points $x \in X$ such that there is an infinite $M \subseteq \mathbb{N}$ such that for every $m \in M$ there is $x_m \in A_m$ with $x_m \rightarrow x$.

In the paper [10] the following result has been proved. See also [13] (5.47.6).

Lemma 2. *Let $\{A_m : m \in \mathbb{N}\}$ be a sequence of connected subsets of a compact metric space X such that some sequence $\{a_n : n \in \mathbb{N}\}$ of points $a_n \in A_n$ is converging in X . Then the set $Ls\{A_n : n \in \mathbb{N}\}$ is compact and connected.*

4. MAIN RESULT

In this section we prove the result mentioned in the abstract.

Let X be a space, and denote by $\Delta(X^2) := \{(x, x) : x \in X\}$. Obviously $\Delta(X^2)$ is homeomorphic to X . Identify S_1 with $I := [0, 1]$ and $0 = 1$.

Suppose that there exists a symmetric retraction r from $S_1 \times S_1$ onto its diagonal $\Delta(S_1^2)$, *i.e.*, a continuous map $r : S_1 \times S_1 \rightarrow \Delta(S_1^2)$ satisfying:

- a) $r(x, y) = r(y, x)$ for each x and y from S_1 , and
- b) $r(x, x) = (x, x)$.

We call r a *2-mean*, and say that S_1 has a 2-mean.

To prove that the existence of $r : S_1^2 \rightarrow \Delta(S_1^2)$ with properties (a-b) is impossible, we consider two cases:

- (1) Assume that $r[(I \times \{1\}) \cup (\{0\} \times I)] \neq \{(0, 0)\}$.

Notice that if we consider I^2 instead of S_1^2 , and $r : I^2 \rightarrow \Delta(I^2)$ rather than $r : S_1^2 \rightarrow \Delta(S_1^2)$, then r has the following additional properties:

- c) $r(0, 0) = (0, 0)$, $r(1, 1) = (1, 1)$,
- d) $r(0, x) = r(1, x)$, $r(x, 0) = r(x, 1)$.

For illustrative purposes, we call $\{0\} \times I :=$ “left”, $\{1\} \times I :=$ “right”, $I \times \{0\} :=$ “bottom” and $I \times \{1\} :=$ “top”. The assumption we are assuming reads now $r[(I \times \{1\}) \cup (\{0\} \times I)] \neq \{(0, 0), (1, 1)\}$. (c) and the Intermediate Value Theorem imply that $r[(I \times \{1\}) \cup (\{0\} \times I)] = \Delta(I^2)$. Fix $k \in \mathbb{N}$, and if $p : I \times I \rightarrow I$ denotes the projection on the first coordinate, define the coloring $f : V(k) \rightarrow \{\pm 1\}$ as follows:

$$f(i/k, j/k) = \begin{cases} -1 & \text{if } \cos(2\pi p(r(i/k, j/k))) \leq 0, \\ 1 & \text{otherwise.} \end{cases}$$

This coloring is symmetric with respect to $\Delta(I^2)$ and each side of the square has exactly the same number of gates: The gates at the left and right sides are at the same vertical positions, and those at the bottom and top sides are at the same horizontal positions, respectively.

Considering once again $r : S_1^2 \rightarrow \Delta(S_1^2)$, we identify the points $(0, i/k)$ with $(1, i/k)$ and $(i/k, 0)$ with $(i/k, 1)$ ($i = 0, \dots, k$). Walking to the right of $(0, 0)$, one finds the first gate g_b^1 (b, l, r and t stand for "bottom", "left", "right" and "top") on $I \times \{0\}$ which gives place to a chain \mathcal{S}_k "going" on top of the \approx -component A of $(0, 0)$ (the relation \approx was defined in the proof of the Combinatorial Lemma). By the case we are dealing with, \mathcal{S}_k intersects $\{0\} \times I$ in the last gate g_l^∞ from top to bottom. By the identification of $(0, i/k)$ with $(1, i/k)$ \mathcal{S}_k reappears through the first gate g_r^1 in $\{1\} \times I$ from bottom to top, and thus \mathcal{S}_k "goes" above the \approx -component B of $(1, 0)$.

\mathcal{S}_k intersects $I \times \{0\}$ in the last gate g_b^∞ going from left to right. By the identification of $(0, i/k)$ with $(1, i/k)$ \mathcal{S}_k reappears through the first gate g_t^1 of the top side from right to left, and thus \mathcal{S}_k "goes" under the \approx -component C of $(1, 1)$. Again \mathcal{S}_k intersects $I \times \{1\}$ in the last gate g_r^∞ of the right side going from bottom to top, thus \mathcal{S}_k reappears on the first gate g_l^1 of the left side going from top to bottom, going under the \approx -component D of $(0, 1)$ and intersecting the last gate g_t^∞ of the top side from right to left, reappearing on g_b^1 and beginning the whole cycle once again. The union of the simplexes from the chain \mathcal{S}_k is a connected set for each natural number k .

According to Lemma 2 the upper limit $C = Ls\{\mathcal{S}_k : k \in \mathbb{N}\}$ is connected, and we have that $C \subset r^{-1}(p^{-1}(\cos^{-1}(0)))$, thus r maps the continuum C onto two points in $\Delta(S_1^2)$; a contradiction.

This concludes the proof in case (1).

(2) Assume that $r[(I \times \{1\}) \cup (\{0\} \times I)] = \{(0, 0)\}$.

This would mean that $r[\partial I^2] = \{(0, 0)\}$, and thus would imply that any copy S of S_1 in the sphere S_2 is a retract: The sphere S_2 is the image of $S_1 \times S_1$ by identifying the left (and right) and bottom (and top) sides of $S_1 \times S_1$. Since S_2 equals the union of two copies of the unit disk, sharing the same boundary, this is impossible by the following corollary to the Combinatorial Lemma:

Corollary 2 (Borsuk's non-retraction theorem). *S_1 is not a retract of the unit disk.*

Proof. Identify the disk with the square I^2 , and S_1 with its boundary ∂I^2 . If $k \in \mathbb{N}$ consider $D^2(k)$ and color it according to what points get mapped to the bottom and left sides, and to the top and right sides. There are only two gates in ∂I^2 . By corollary 1 there is one and only one chain connecting these two gates. Then we proceed similarly as in the end of case (1). \square

REFERENCES

1. G. AUMANN and C. CARETHÉODORY, *Ein Satz über die konforme Abbildung mehrfach zusammenhängender ebener Gebiete*, Math. Annalen **109** (1934), 756–763.

2. G. AUMANN, *Aufbau von Mittelwerten mehrerer Argumente II (Analytische Mittelwerte)*, Math. Annalen **111** (1935), 713–730.
3. G. AUMANN, *Über Räume mit Mittelbildungen*, Math. Annalen **119** (1943), 210–215.
4. K. BORSUK, *Drei Sätze über die n -dimensionale Euklidische Sphäre*, Fund. Math. **21** (1933), 177–190.
5. J. DUGUNDJI and A. GRANAS *Fixede point theory*, PWN-Polish Scientific Publisher 1982.
6. D. GALE, *The game of hex and the Brouwer fixed-point theorem*, Amer. Math. Monthly **86** (1979), 818–827.
7. K. FAN, *A generalization of Tucker's combinatorial lemma with topological applications*, Ann. of Math., **56** (3) (1952), 431–437.
8. P. HILTON, *A new look at means on topological spaces*, Internat. J. Math. & Math. Sci., **20** (4) (1997), 617–620.
9. B. KNASTER, C. KURATOWSKI and S. MAZURKIEWICZ, *Ein Beweis Fixpunktsatzes für n -dimensionale Simplexe*, Fund. Math. **14** (1929), 132–137.
10. W. KULPA, L. SOCHA and M. TURZAŃSKI, *Parametric extension of the Poincaré Theorem*, Acta Universitatis Carolinae–Mathematica et Physica, **41** (2) (2000), 39–46.
11. W. KULPA, L. SOCHA and M. TURZAŃSKI, *Steinhaus Chessboard Theorem*, Acta Universitatis Carolinae–Mathematica et Physica, **41** (2) (2000), 47–50.
12. W. KULPA and M. TURZAŃSKI, *A Combinatorial Theorem for a Symmetric Triangulation of the Sphere S_2* , Acta Universitatis Carolinae–Mathematica et Physica, **42** (2) (2002), 69–74.
13. K. KURATOWSKI, *Topology, vol. II*, Academic Press, New York, 1968.
14. E. SPERNER, *Neuer Beweis für die Invarianz der Dimensionzahl und des Gebietes*, Abh. Math. Sem. Ham. Univ. **6** (1928), 265–272.
15. A. W. TUCKER, *Some topological properties of disk and sphere*, Proc. First Canadian Math. Congress (Montreal, 1945), 285–309.
16. M. TURZAŃSKI, *On the structure of the set of zeros of the continuous real valued function defined on square*, preprint.

DEPARTMENT OF MATHEMATICS, CALIFORNIA STATE UNIVERSITY, BAKERSFIELD, 9011 STOCKDALE HIGHWAY, BAKERSFIELD, CALIFORNIA 93311-1099, USA
E-mail address: `jtrigos@csubak.edu`

DEPARTMENT OF MATHEMATICS, CARDINAL STEFAN WYSZYŃSKI UNIVERSITY, UL. DEWAJTIS 5, 01-815 WARSAW, POLAND
E-mail address: `mtturz@ux2.math.us.edu.pl`